

# 50-T



- power to lift.

# HMF T-Boom Range Loader 50-T

## 50-T – the small Giant

- A compact loader with low tare weight
- Simple and safe operation
- Lifts 430 kg at 1.2 metres
- Also available as standard model with winch
- Few wearing parts
- Ideal for fitting in vans
- Fixed or separate stabilizer legs available as optional extra

Loading group B2		50-T-M
Load moment	tm	0.5
Lifting capacity at min. reach	m/kg	1.2 - 430
Lifting capacity at max. reach	m/kg	2.0 - 250
Slewing angle	°	360
Height above chassis	mm	1230
Max. lifting height above base	m	3.20
Hand pump	cm <sup>3</sup> /doub. stroke	12
Working pressure	MPa	18.5
Tank		In separate hand pump
Weight	kg	62

Loading group B2		50-T0 with winch
Lifting capacity at max. reach	m/kg	1.2 - 450
Height above chassis	mm	1270

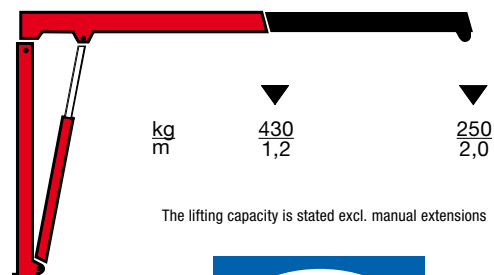
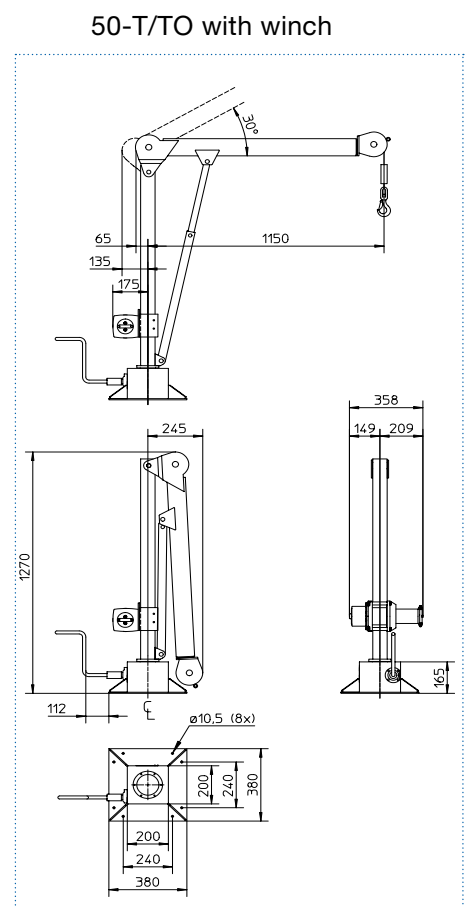
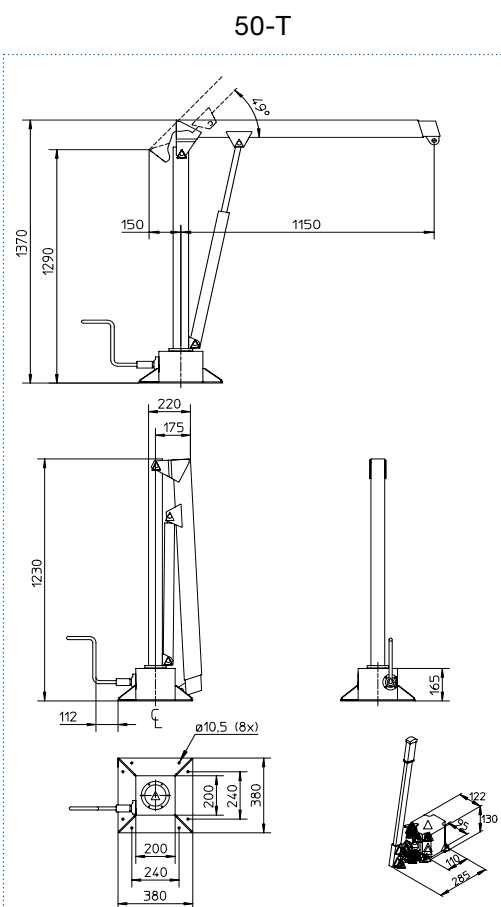
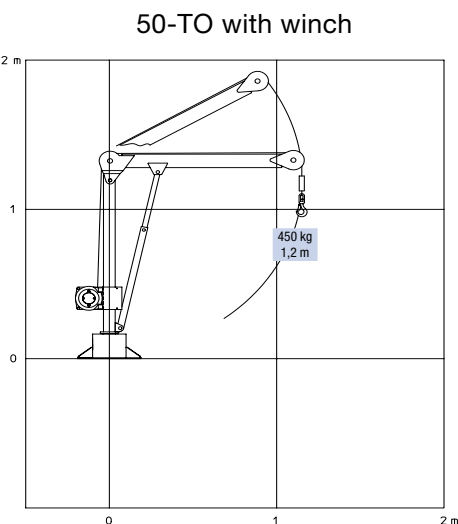
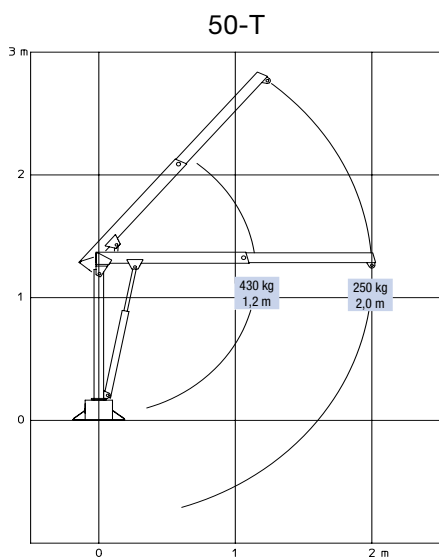

The lifting capacity is stated excl. manual extensions



Z008030 - 1

We reserve the right to introduce improvements and modifications

Højbjerg Maskinfabrik A/S • Oddervej 200 • DK-8270 Højbjerg  
Tel.: +45 8627 0800 • Fax: +45 8627 0744 • info@hmf.dk

www.hmf.dk