

270-K



- power to lift.

HMF Knuckle Boom Loader 270-K

Fast and easy to handle

- Very compact installation with a long reach.
- The loader has a low tare weight, which gives an improved payload on the vehicle.
- Suitable for many different purposes thanks to optimized boom geometry.
- Available with two or three hydraulic extensions.
- Reliable and sturdy design.
- Available with radio remote control as an option.
- Available with 2 extra valves for grab and rotator in the K2 version.

Loading group B3		270-K2	270-K3
Load moment	tm	2.5	2.4
Hydraulic reach	m	5.6	7.0
Slewing torque	kgm	390	390
Slewing angle	°	370	370
Height above chassis	mm	1527	1527
Width, folded, standard	mm	1700	1700
Width, folded, extra	mm	2000	2000
Length of base, no extra valves	mm	538	564
Stabilizer spread, standard	mm	3000	3000
Stabilizer spread, long	mm	3900	3900
Weight excl. stabilizers	kg	386	421
Weight of stabilizers, standard	kg	59	59
Working pressure	MPa	19.0	19.0
Pump performance	l/min	12	10
Power consumption	kW	4	3.5
Oil tank capacity, separate tank	l	15	15

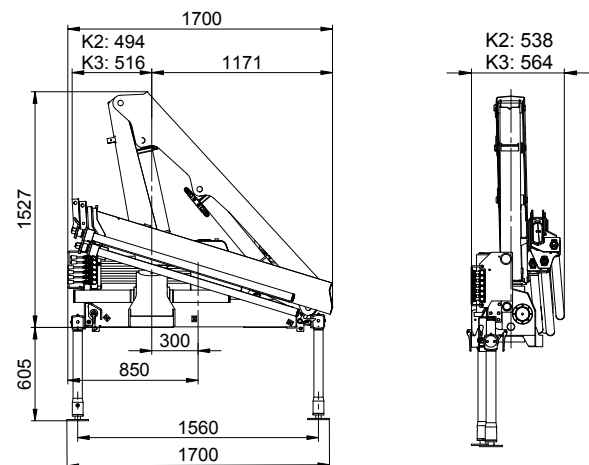
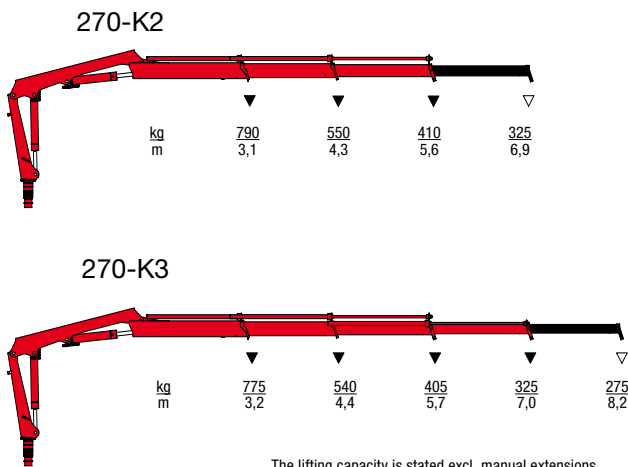
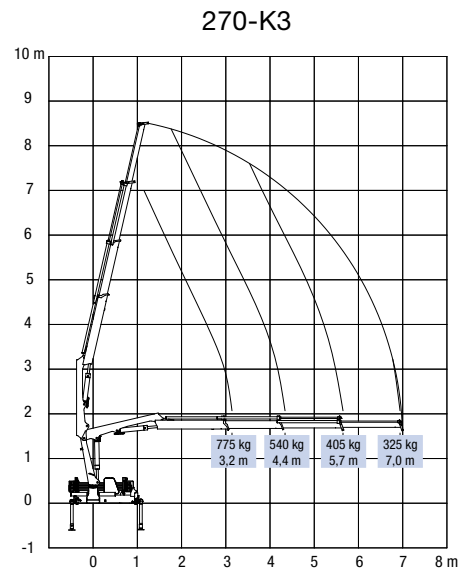
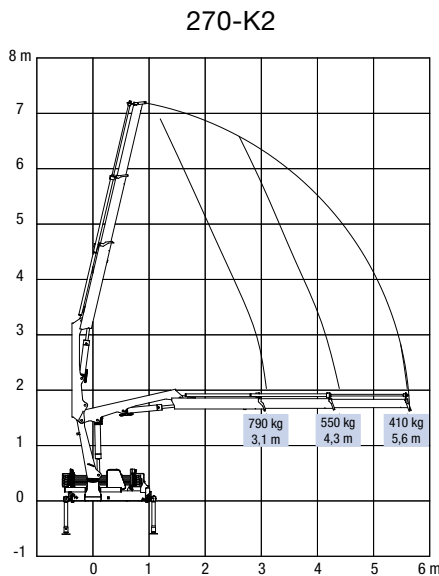

Z008069-2



Højbjerg Maskinfabrik A/S • Oddervej 200 • DK-8270 Højbjerg
Tel.: +45 8627 0800 • Fax: +45 8627 0744 • info@hmf.dk

www.hmf.dk

We reserve the right to introduce improvements and modifications